

SCK 306

SCARRABILE CON SFILO, RIBALTAMENTO E ARTICOLAZIONE

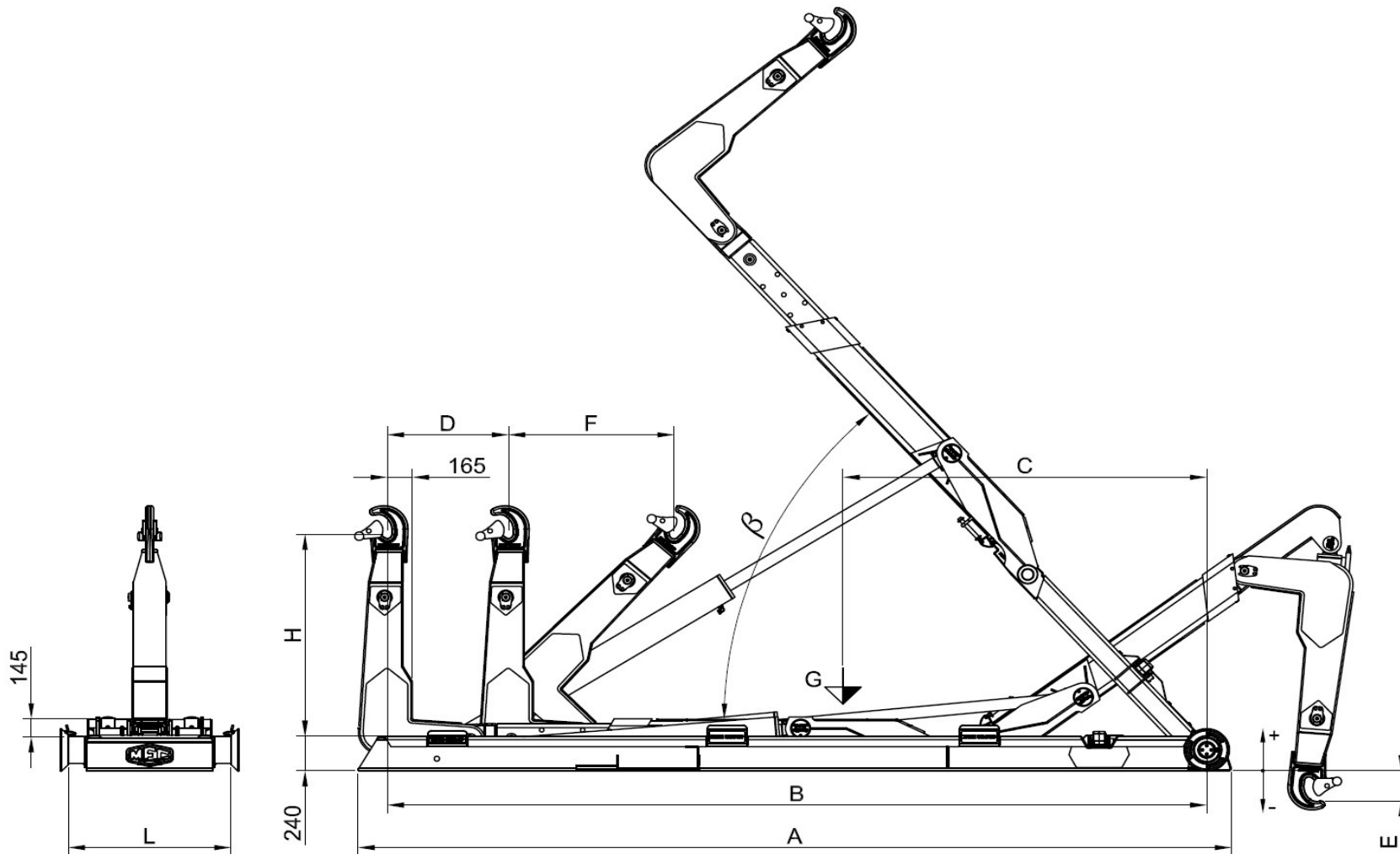

Modèle Equip	PTAC Minimum conseillée	Poids Equip	Angle	Debit conseillée de la pompe	Pression Max	Capacité maximale de charge	Dimensions								Caisson conseillé	
Equipment Model	Minimum GVW recommended	Equip Weight	Angle	Recomm. pump flow	Max Pressure	Maximum loading capacity	Dimensions								Recommended container	
Modello Scarrabile	PTT Minimo consigliato	Peso Scarr.	Angolo	Portata consigliata della pompa	Pressione Max	Capacità massima di carico	Dimensioni								Cassa consigliata	
	TON	Kg	β	Litri / min	Bar	TON	A	B	C	D	H	E	F	L	MIN	MAX
SCK 306 NC	32	2890	58°	95	340	30	5160	4810	2790	800	1430 / 1570	-360 / -500	1090 / 1180	1070	3000	5500
SCK 306 N	32	2930	54°	95	340	30	5360	5010	2890	800	1430 / 1570	-360 / -500	1090 / 1180	1070	3200	5700
SCK 306 NL	32	2990	59°	95	340	30	5560	5210	3040	800	1430 / 1570	-460 / -600	1090 / 1180	1070	3400	5900
SCK 306 L	32	3030	54°	95	340	30	5760	5410	3130	800	1430 / 1570	-460 / -600	1090 / 1180	1070	3600	6100
SCK 306 XL	32	3070	54°	95	340	30	5960	5610	3220	1000	1430 / 1570	-460 / -600	1090 / 1180	1070	3600	6300
SCK 306 XXL	32	3110	54°	95	340	30	6195	5845	3320	1235	1430 / 1570	-460 / -600	1090 / 1180	1070	3600	6500