

SCK 267

SCARRABILE CON SFILO, RIBALTAMENTO E ARTICOLAZIONE

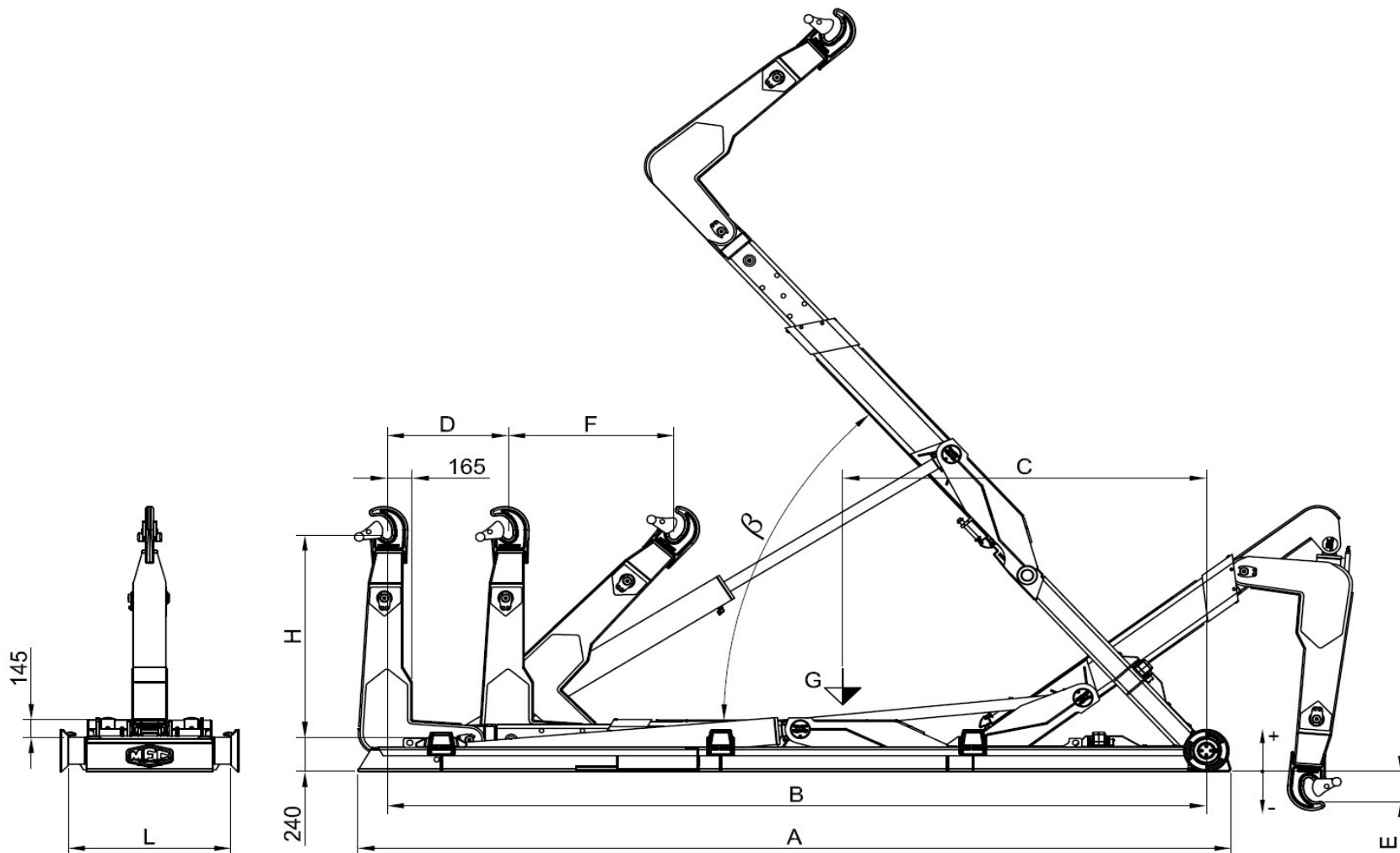

Modèle Equip	PTAC Minimum conseillée	Poids Equip	Angle	Debit conseillée de la pompe	Pression Max	Capacité maximale de charge	Dimensions										Caisson conseillé
Equipment Model	Minimum GVW recommended	Equip Weight	Angle	Recomm. pump flow	Max Pressure	Maximum loading capacity	Dimensions										Recommended container
Modello Scarrabile	PTT Minimo consigliato	Peso Scarr.	Angolo	Portata consigliata della pompa	Pressione Max	Capacità massima di carico	Dimensioni										Cassa consigliata
	TON	Kg	β	Litri / min	Bar	TON	A	B	C	D	H	E	F	L	MIN	MAX	
SCK 267 NC	26	2970	58°	90	340	24	6350	5995	3410	1235	1430 / 1570	-280 / -420	1090 / 1180	1070	3800	6700	
SCK 267 N	26	3010	54°	90	340	24	6550	6195	3520	1235	1430 / 1570	-280 / -420	1090 / 1180	1070	4000	6900	
SCK 267 NL	26	3050	51°	90	340	24	6750	6395	3630	1235	1430 / 1570	-280 / -420	1090 / 1180	1070	4200	7100	
SCK 267 L	26	3090	48°	90	340	24	6950	6595	3730	1235	1430 / 1570	-280 / -420	1090 / 1180	1070	4400	7300	