

SCK 266

SCARRABILE CON SFILO, RIBALTAMENTO E ARTICOLAZIONE

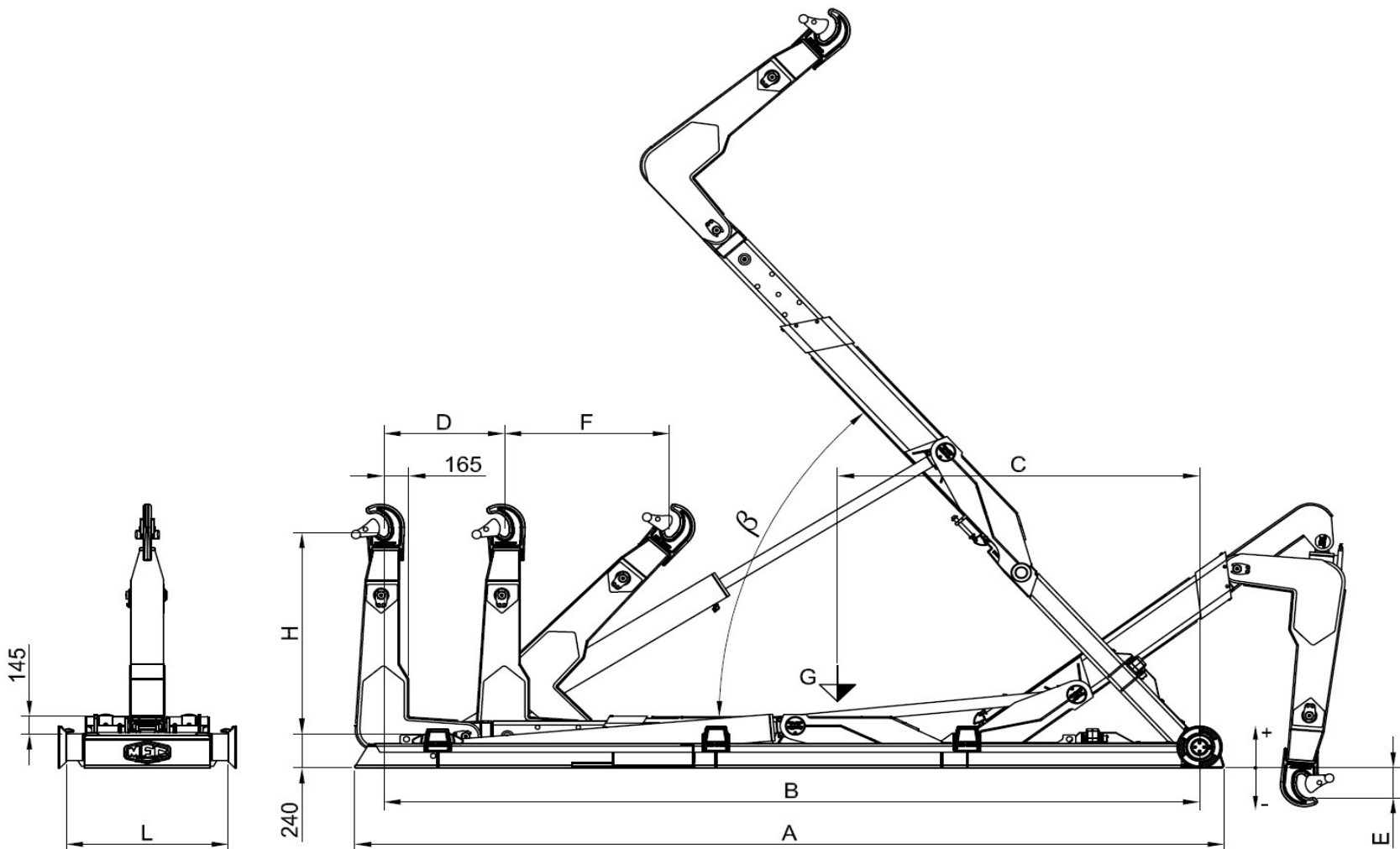

Modèle Equip	PTAC Minimum conseillée	Poids Equip	Angle	Debit conseillée de la pompe	Pression Max	Capacité maximale de charge	Dimensions								Caisson conseillé	
Equipment Model	Minimum GVW recommended	Equip Weight	Angle	Recomm. pump flow	Max Pressure	Maximum loading capacity	Dimensions								Recommended container	
Modello Scarrabile	PTT Minimo consigliato	Peso Scarr.	Angolo	Portata consigliata della pompa	Pressione Max	Capacità massima di carico	Dimensioni								Cassa consigliata	
	TON	Kg	β	Litri / min	Bar	TON	A	B	C	D	H	E	F	L	MIN	MAX
SCK 266 NC	26	2720	58°	80	340	24	5160	4810	2770	800	1430 / 1570	-360 / -500	1090 / 1180	1070	3000	5500
SCK 266 N	26	2760	54°	80	340	24	5360	5010	2870	800	1430 / 1570	-360 / -500	1090 / 1180	1070	3200	5700
SCK 266 NL	26	2820	59°	80	340	24	5560	5210	3020	800	1430 / 1570	-460 / -600	1090 / 1180	1070	3400	5900
SCK 266 L	26	2860	54°	80	340	24	5760	5410	3110	800	1430 / 1570	-460 / -600	1090 / 1180	1070	3600	6100
SCK 266 XL	26	2900	54°	80	340	24	5960	5610	3200	1000	1430 / 1570	-460 / -600	1090 / 1180	1070	3600	6300
SCK 266 XXL	26	2940	54°	80	340	24	6195	5845	3300	1235	1430 / 1570	-460 / -600	1090 / 1180	1070	3600	6500