

SCK 207

SCARRABILE CON SFILO, RIBALTAMENTO E ARTICOLAZIONE

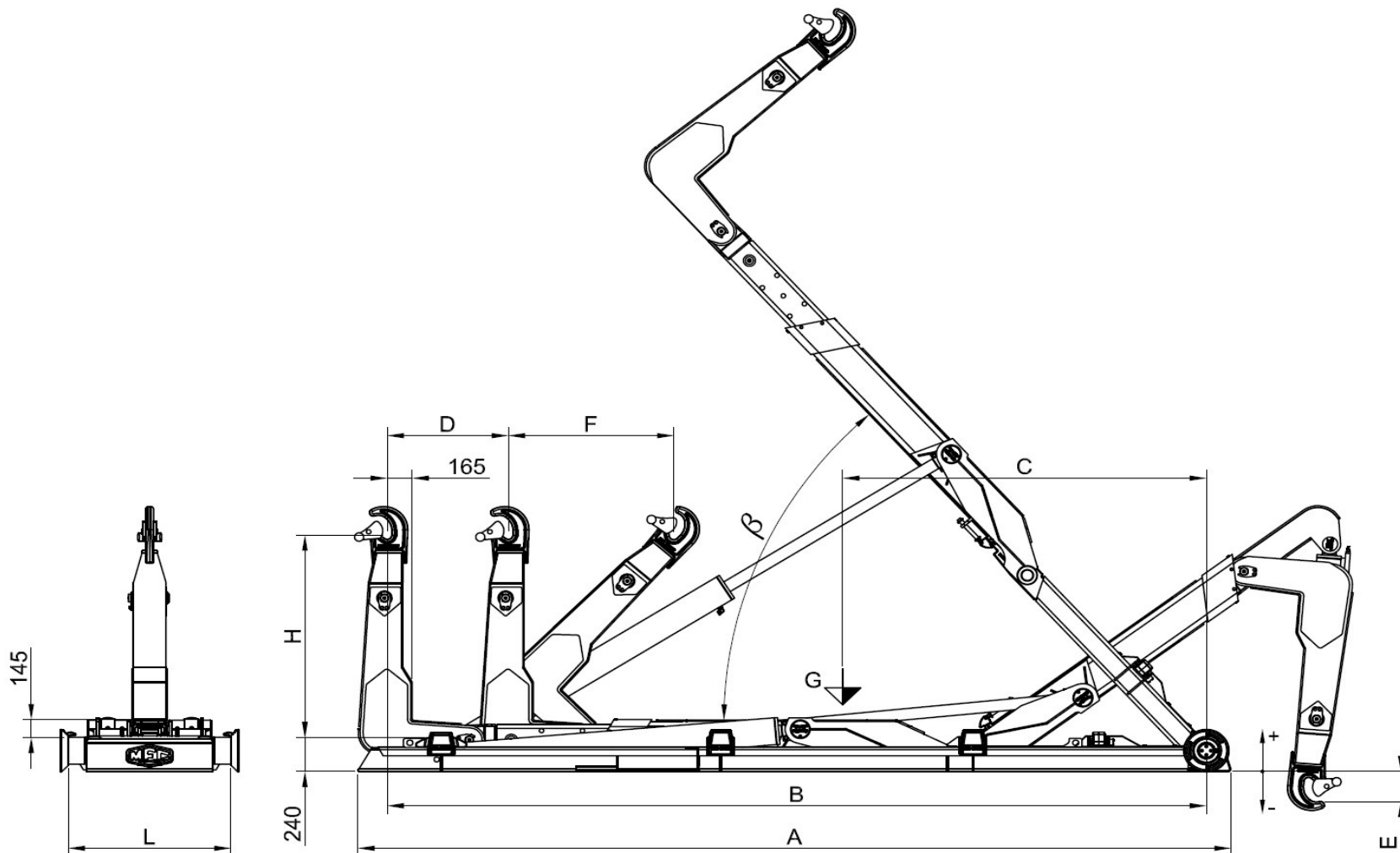

Modèle Equip	PTAC Minimum conseillée	Poids Equip	Angle	Debit conseillée de la pompe	Pression Max	Capacité maximale de charge	Dimensions								Caisson conseillé	
Equipment Model	Minimum GVW recommended	Equip Weight	Angle	Recomm. pump flow	Max Pressure	Maximum loading capacity	Dimensions								Recommended container	
Modello Scarrabile	PTT Minimo consigliato	Peso Scarr.	Angolo	Portata consigliata della pompa	Pressione Max	Capacità massima di carico	Dimensioni								Cassa consigliata	
	TON	Kg	β	Litri / min	Bar	TON	A	B	C	D	H	E	F	L	MIN	MAX
SCK 207 NC	26	2850	58°	75	340	20	6350	5995	3410	1235	1430 / 1570	-280 / -420	1090 / 1180	1070	3800	6700
SCK 207 N	26	2890	54°	75	340	20	6550	6195	3520	1235	1430 / 1570	-280 / -420	1090 / 1180	1070	4000	6900
SCK 207 NL	26	2930	51°	75	340	20	6750	6395	3630	1235	1430 / 1570	-280 / -420	1090 / 1180	1070	4200	7100
SCK 207 L	26	2970	48°	75	340	20	6950	6595	3730	1235	1430 / 1570	-280 / -420	1090 / 1180	1070	4400	7300