

SC 306

SCARRABILE CON SFILLO E RIBALTAMENTO

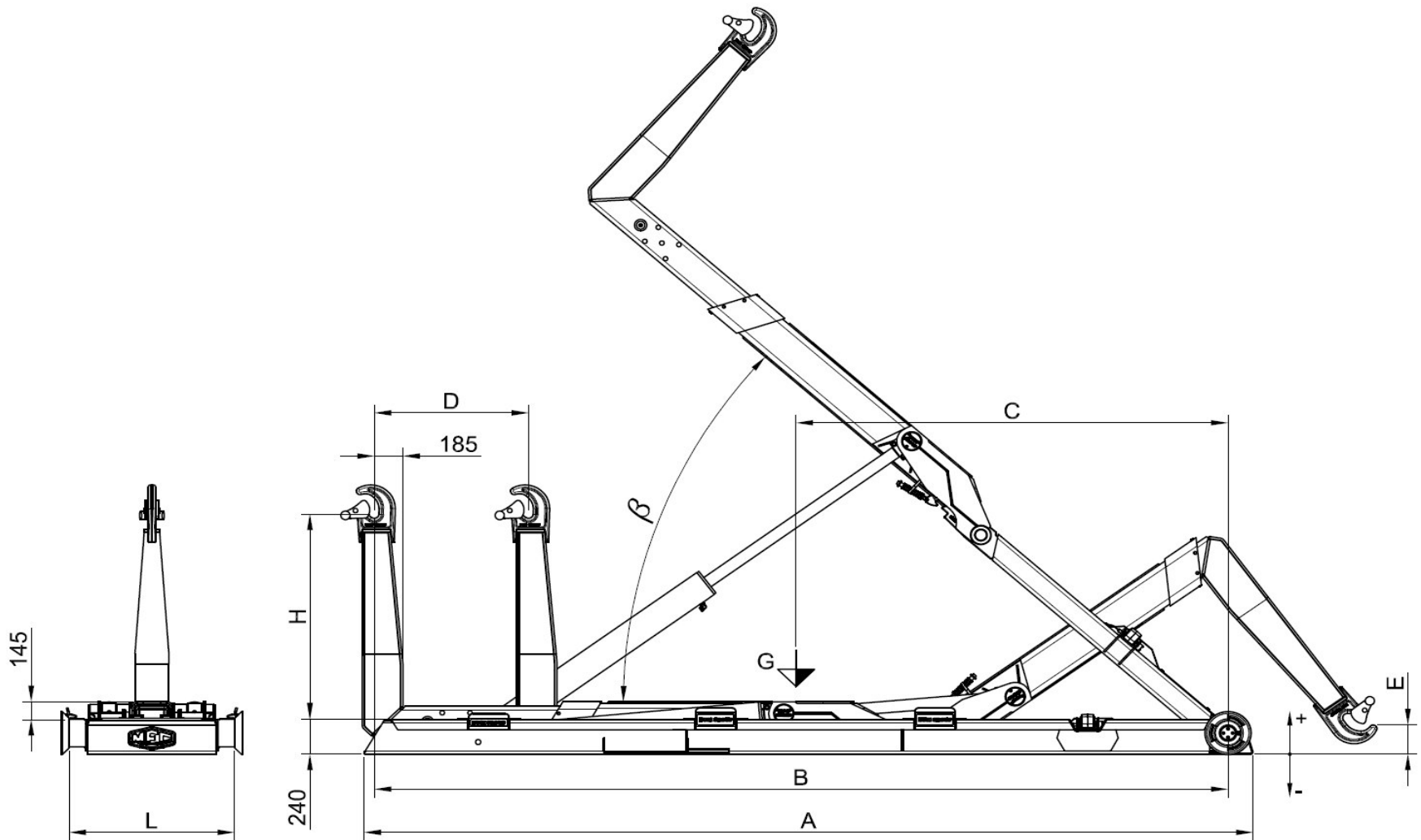

Modèle Equip	PTAC Minimum conseillée	Poids Equip	Angle	Debit conseillée de la pompe	Pression Max	Capacité maximale de charge	Dimensions						Caisson conseillé		
Equipment Model	Minimum GVW recommended	Equip Weight	Angle	Recomm. pump flow	Max Pressure	Maximum loading capacity	Dimensions						Recommended container		
Modello Scarrabile	PTT Minimo consigliato	Peso Scarr.	Angolo	Portata consigliata della pompa	Pressione Max	Capacità massima di carico	Dimensioni						Cassa consigliata		
	TON	Kg	β	Litri / min	Bar	TON	A	B	C	D	H	E	L	MIN	MAX
SC 306 XC	32	2560	54°	95	340	30	4760	4530	2880	1000	1430 / 1570	100 / -30	1070	3600	5200
SC 306 C	32	2600	51°	95	340	30	4960	4730	2930	1000	1430 / 1570	100 / -30	1070	3800	5400
SC 306 NC	32	2640	48°	95	340	30	5160	4930	2980	1000	1430 / 1570	100 / -30	1070	4000	5600
SC 306 N	32	2670	48°	95	340	30	5360	5130	3050	1000	1430 / 1570	220 / 90	1070	4200	5800
SC 306 NL	32	2710	45°	95	340	30	5560	5330	3100	1000	1430 / 1570	220 / 90	1070	4400	6000
SC 306 L	32	2760	42°	95	340	30	5760	5530	3150	1000	1430 / 1570	220 / 90	1070	4600	6200
SC 306 XL	32	2800	42°	95	340	30	5860	5630	3180	1100	1430 / 1570	220 / 90	1070	4600	6300