

SC 018/7

SCARRABILE CON FILO E RIBALTAMENTO

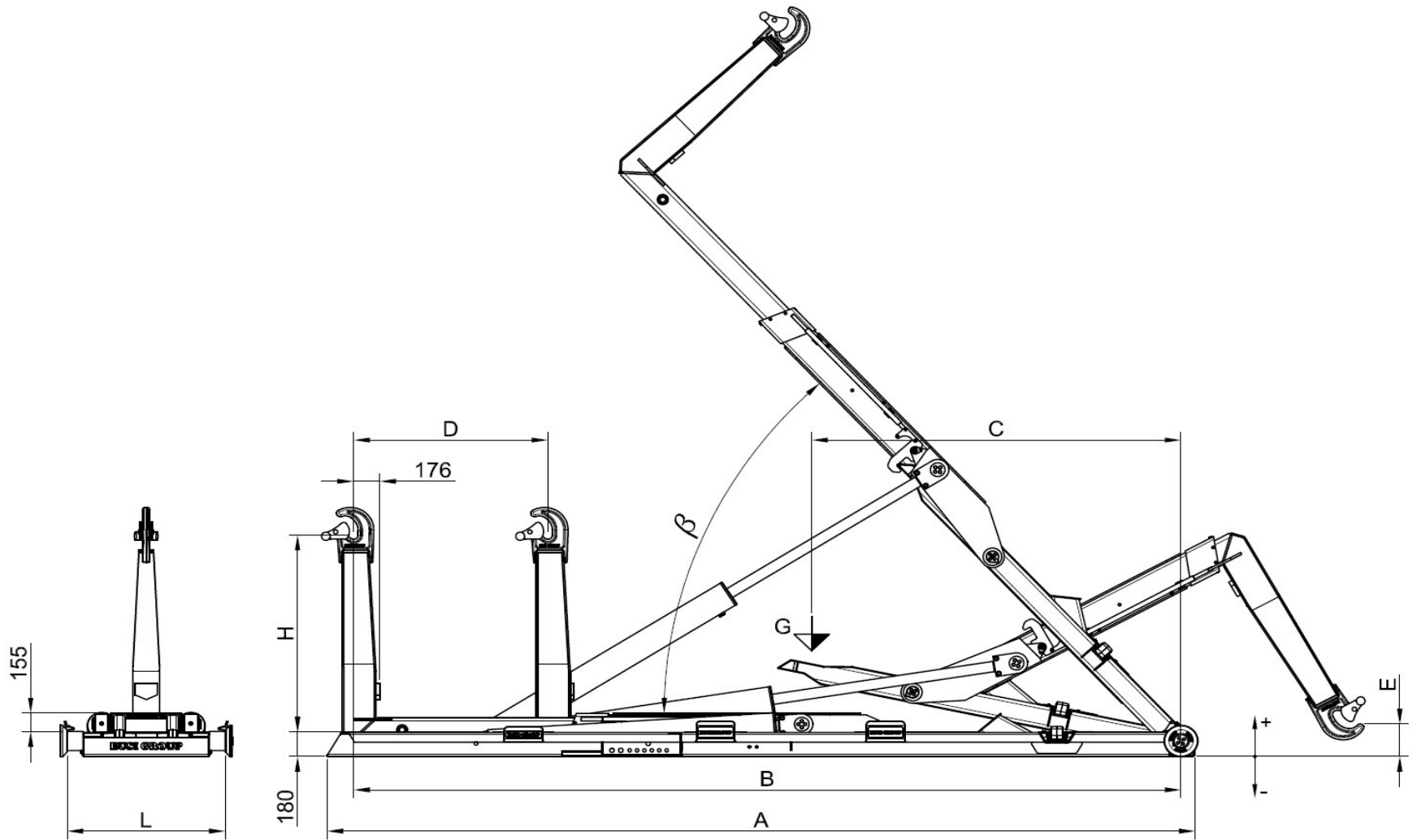

Modèle Equip	PTAC Minimum conseillée	Poids Equip	Angle	Debit conseillée de la pompe	Pression Max	Capacité maximale de charge	Dimensions						Caisson conseillé		
Equipment Model	Minimum GVW recommended	Equip Weight	Angle	Recomm. pump flow	Max Pressure	Maximum loading capacity	Dimensions						Recommended container		
Modello Scarrabile	PTT Minimo consigliato	Peso Scarr.	Angolo	Portata consigliata della pompa	Pressione Max	Capacità massima di carico	Dimensioni						Cassa consigliata		
	TON	Kg	β	Litri / min	Bar	TON	A	B	C	D	H	E	L	MIN	MAX
SC 018 / 58	18	2230	53°	60	340	18	6075	5800	3230	1115	1430 / 1570	-10 / -150	1070	4800	6400
SC 018 / 60	18	2240	53°	60	340	18	6275	6000	3270	1315	1430 / 1570	-10 / -150	1070	4800	6600
SC 018 / 62	18	2280	53°	60	340	18	6475	6200	3330	1315	1430 / 1570	10 / -130	1070	5000	6800
SC 018 / 64	18	2290	53°	60	340	18	6675	6400	3370	1515	1430 / 1570	10 / -130	1070	5000	7000