

# SC 016

SCARRABILE CON SFILLO E RIBALTAMENTO

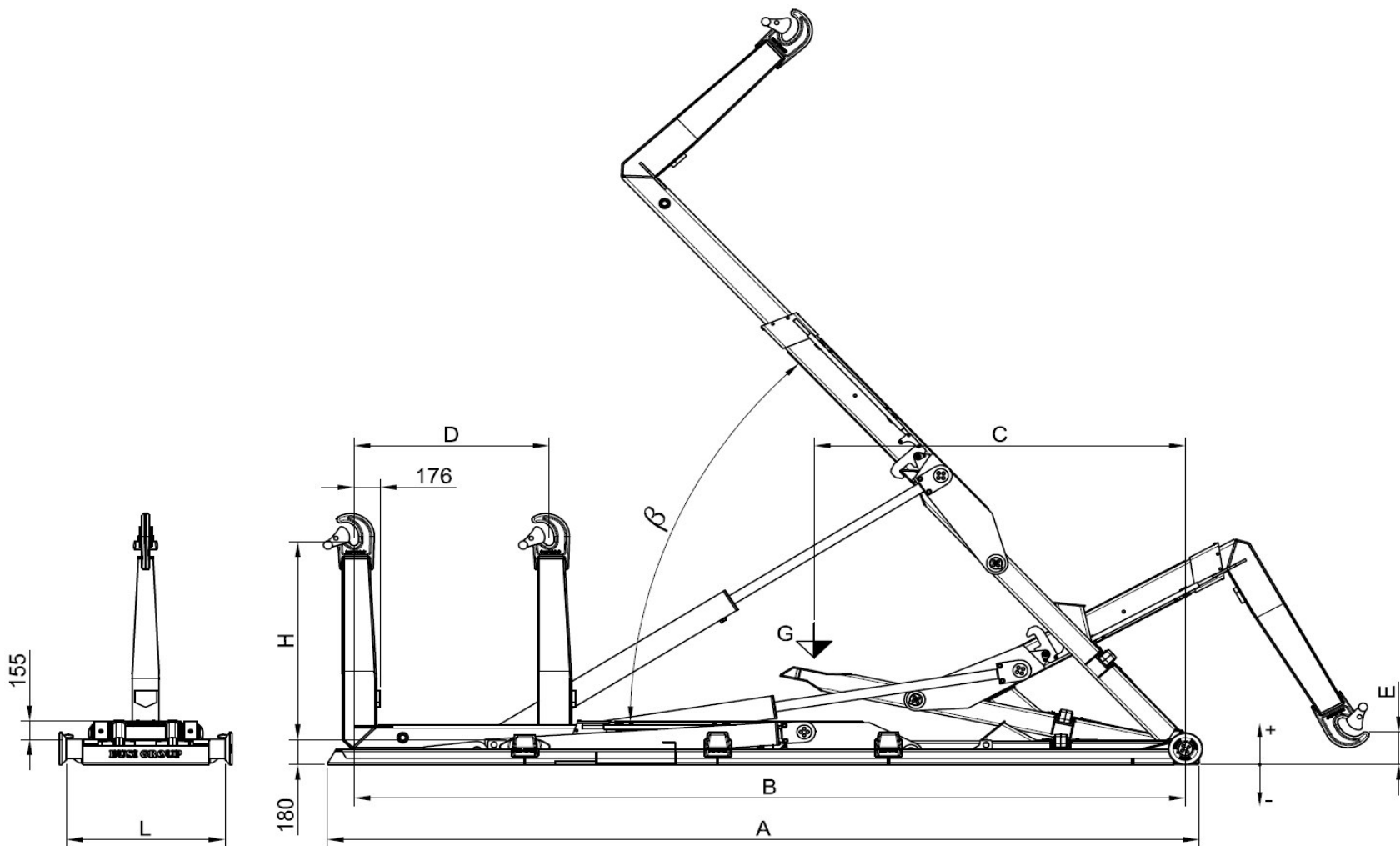

Modèle Equip	PTAC Minimum conseillée	Poids Equip	Angle	Debit conseillée de la pompe	Pression Max	Capacité maximale de charge	Dimensions						Caisson conseillé		
Equipment Model	Minimum GWV recommended	Equip Weight	Angle	Recomm. pump flow	Max Pressure	Maximum loading capacity	Dimensions						Recommended container		
Modello Scarrabile	PTT Minimo consigliato	Peso Scarr.	Angolo	Portata consigliata della pompa	Pressione Max	Capacità massima di carico	Dimensioni						Cassa consigliata		
	TON	Kg	β	Litri / min	Bar	TON	A	B	C	D	H	E	L	MIN	MAX
SC 016 / 42	18	1840	58°	50	320	16	4525	4200	2300	915	1430 / 1570	-165 / -290	1070	3400	4800
SC 016 / 44	18	1860	54°	50	320	16	4725	4400	2440	915	1430 / 1570	-80 / -205	1070	3600	5000
SC 016 / 46	18	1890	54°	50	320	16	4875	4600	2490	915	1430 / 1570	10 / -115	1070	3800	5200
SC 016 / 48	18	1900	54°	50	320	16	5075	4800	2530	1115	1430 / 1570	10 / -115	1070	3800	5400
SC 016 / 50	18	1980	52°	50	320	16	5475	5000	2820	915	1430 / 1570	-95 / -230	1070	4200	5600
SC 016 / 52	18	1980	52°	50	320	16	5475	5200	2850	1115	1430 / 1570	-95 / -230	1070	4200	5800
SC 016 / 54	18	2010	52°	50	320	16	5675	5400	2910	1115	1430 / 1570	-45 / -175	1070	4400	6000
SC 016 / 56	18	2020	52°	50	320	16	5875	5600	2940	1315	1430 / 1570	-45 / -175	1070	4400	6200