

# SC 006

SCARRABILE CON SFILLO E RIBALTAMENTO

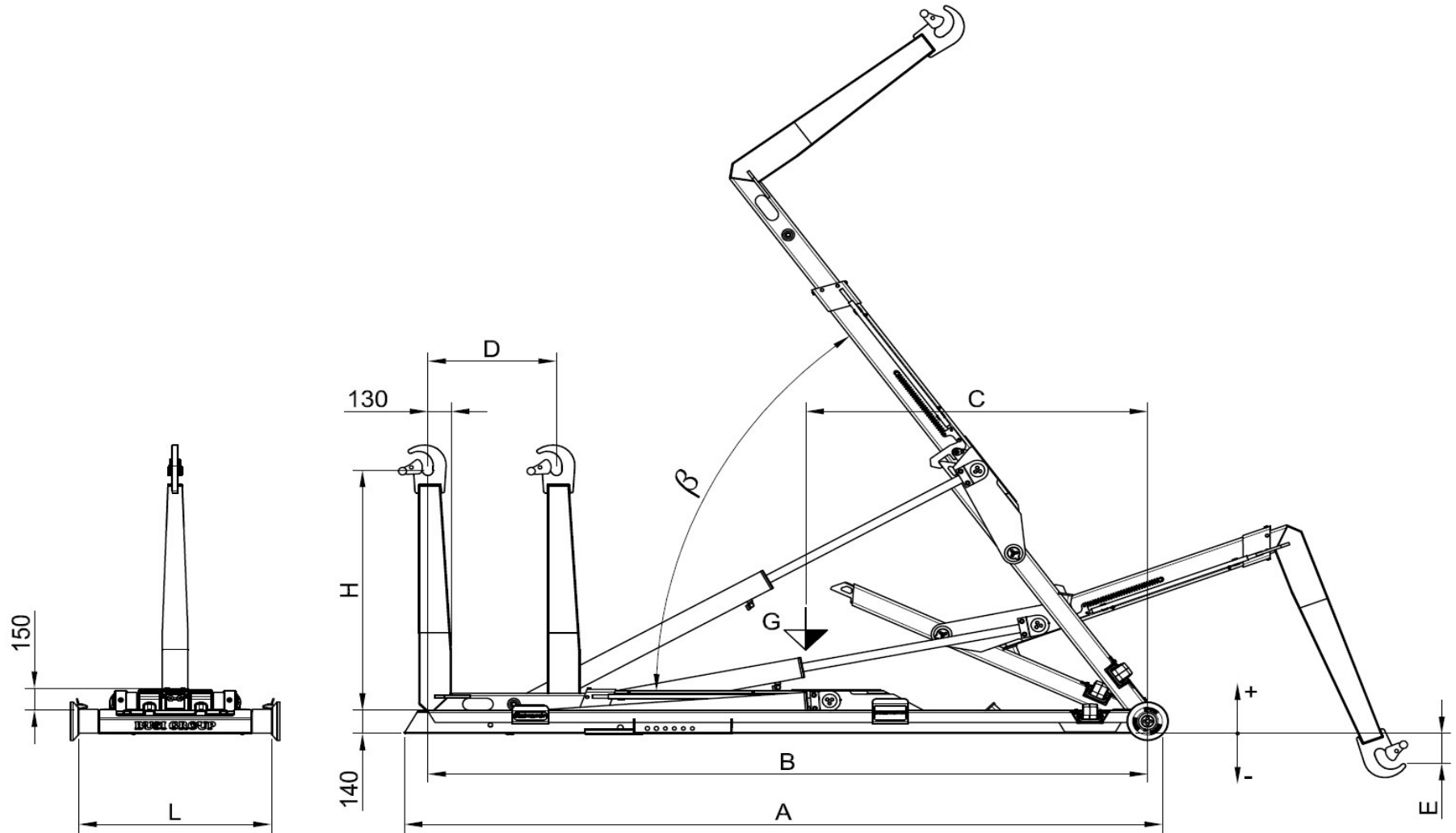

Modèle Equip	PTAC Minimum conseillée	Poids Equip	Angle	Debit conseillée de la pompe	Pression Max	Capacité maximale de charge	Dimensions							Caisson conseillé	
Equipment Model	Minimum GVW recommended	Equip Weight	Angle	Recomm. pump flow	Max Pressure	Maximum loading capacity	Dimensions							Recommended container	
Modello Scarrabile	PTT Minimo consigliato	Peso Scarr.	Angolo	Portata consigliata della pompa	Pressione Max	Capacità massima di carico	Dimensioni							Cassa consigliata	
	TON	Kg	$\beta$	Litri / min	Bar	TON	A	B	C	D	H	E	L	MIN	MAX
SC 006 / 32	7,5	920	67°	30	290	6	3415	3200	1570	515	900 / 1430	-285 / -795	1070	2800	3600
SC 006 / 34	7,5	960	60°	30	290	6	3615	3400	1700	515	900 / 1430	-20 / -520	1070	3000	3800
SC 006 / 36	7,5	990	60°	30	290	6	3815	3600	1740	715	900 / 1430	-20 / -520	1070	3000	4000
SC 006 / 38	7,5	1080	62°	30	290	6	4015	3800	1960	715	900 / 1430	-110 / -620	1070	3200	4200
SC 006 / 40	7,5	1120	62°	30	290	6	4215	4000	2020	715	900 / 1430	-110 / -620	1070	3400	4400
SC 006 / 42	7,5	1150	62°	30	290	6	4415	4200	2050	915	900 / 1430	-110 / -620	1070	3400	4600
SC 006 / 44	7,5	1210	63°	30	290	6	4615	4400	2230	915	900 / 1430	-98 / -605	1070	3600	4800