

KT 25 / 6

SCARRABILE CON SFILLO E RIBALTAMENTO

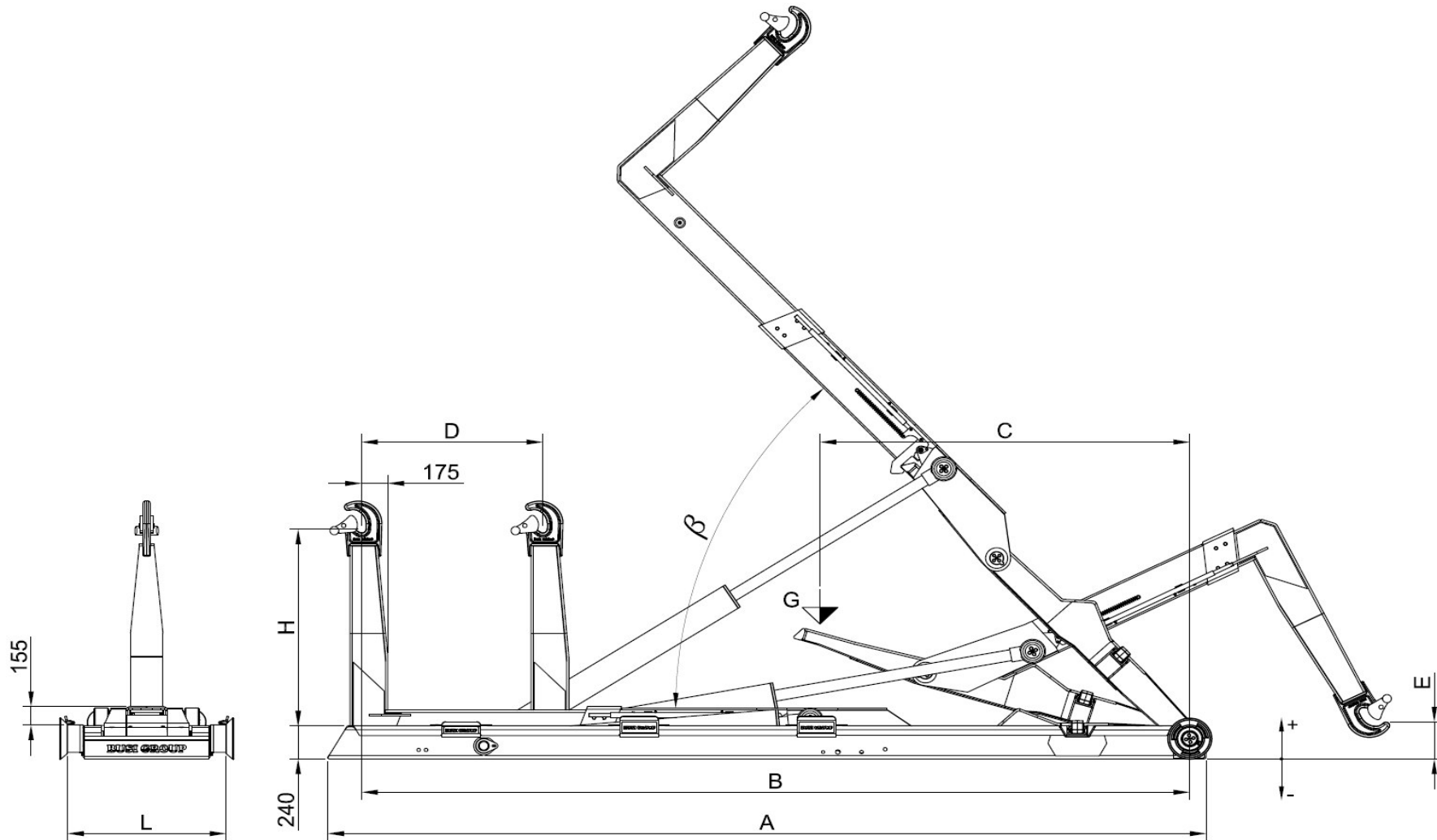

Modèle Equip	PTAC Minimum conseillée	Poids Equip	Angle	Debit conseillée de la pompe	Pression Max	Capacité maximale de charge	Dimensions						Caisson conseillé		
Equipment Model	Minimum GVW recommended	Equip Weight	Angle	Recomm. pump flow	Max Pressure	Maximum loading capacity	Dimensions						Recommended container		
Modello Scarrabile	PTT Minimo consigliato	Peso Scarr.	Angolo	Portata consigliata della pompa	Pressione Max	Capacità massima di carico	Dimensioni						Cassa consigliata		
	TON	Kg	β	Litri / min	Bar	TON	A	B	C	D	H	E	L	MIN	MAX
KT 25 / 50	26	2580	52°	80	340	25	5340	5000	2950	825	1430 / 1570	10 / -120	1070	4300	5600
KT 25 / 52	26	2610	52°	80	340	25	5540	5200	3000	1025	1430 / 1570	10 / -120	1070	4300	5800
KT 25 / 54	26	2640	52°	80	340	25	5740	5400	3050	1225	1430 / 1570	10 / -120	1070	4300	6000
KT 25 / 56	26	2680	52°	80	340	25	5940	5600	3100	1225	1430 / 1570	70 / -60	1070	4500	6200